

Mayor & Board of Aldermen – Regular Meeting

Meeting Minutes

March 19, 2026

Present: Mayor Adrain Wiggins
Vice Mayor Cates
Aldermen Austin, Bailey, Campbell and LaBudde

Prayer and Pledge of Allegiance to the American Flag

1. Call to order by Mayor Wiggins
2. Establish Quorum
All present
3. Prayer & Pledge of Allegiance to the American Flag
4. Approval of Agenda

Town Manager Ellis requested the following changes:

- A. Add Item I: *Resolution 26-18 Request for Proposals for Managed Multifunction Copier Equipment and Services*, under XV Consideration of Resolutions: New Business; and,
- B. Remove Item H: *Resolution 26-17 Shelby Electric*, under XV Consideration of Resolutions: New Business; and,
- C. Remove Item A: *Ordinance 26-03 Billing Procedures and Rates*, under XIII New Business: Ordinance First Reading

Vice Mayor Cates made a motion to approve the agenda as amended. Alderman Bailey seconded the motion. All in favor, none opposed. The motion passed.

5. Reading and Correction/Approval of Minutes

A. February 11, 2026 – Work Session Minutes

Alderman Bailey made a motion to approve the February 11, 2026 Work Session minutes. Vice Mayor Cates seconded the motion. All in favor, none opposed. The motion passed.

B. February 19, 2026– Regular Board Meeting Minutes

Alderman Labudde made a motion to approve the February 19, 2026 Regular Meeting minutes. Alderman Austin seconded the motion. All in favor, none opposed. The motion passed.

6. Special Item:

- A. Mayor Wiggins recognized Harley McNeal, of Code Enforcement, for the multiple ICC Certifications she recently attained. In appreciation, of the difficult task (in a short amount of time), Mayor Wiggins presented a plaque to her, as he announced she received certifications in: Residential Building, Residential Plumbing and Residential Mechanical, all in the past 16 months.
- B. Chelsea Williams Kivelle, an Oakland resident, addressed the Board of Alderman of an on-going issue pertaining to her property. She presented a timeline document that included pictures of the problem.

7. Citizens' Comments:

Gary Schmidt – Pinehurst Drive– Mr. Schmidt spoke to the Board of Mayor and Aldermen regarding Resolution 26-14, the TN Soccer Academy Agreement. Mr. Schmidt stated he had researched TN Soccer Academy, finding the entity is contracted with Arlington. In reaching out to Arlington, he was informed that Oakland was being charged far less, and they (Arlington) do not supply the goals and nets. Mr. Schmidt pointed out the Agreement is specific that the Town of Oakland will provide a total of “32 **KWIK Goal Brand goals and nets**”, a current pricing of \$50k. Based on the proposed agreement and the maximum number of past soccer participants, 266 multiplied by \$20, the Town of Oakland would receive \$5,320 in revenue, taking 10 years to recoup the expense of goals & nets. He said there are other expenses associated with the agreement, such as man-hours, maintenance, equipment and lighting costs, that is concerning. He suggested to the Board further review is necessary, prior to passing Resolution 26-14 and signing the TN Soccer Academy Agreement.

Ramona Olsen – Burr Oak Drive– Ms. Olsen spoke on her *husband's behalf* related to Resolution 26-10, Water Leak Protection Insurance. His questions pertaining to the proposed leak insurance were the following: coverage limits, all associated fees, and who will oversee the administrative duties? He shared his opposition to an auto enrollment of all customers, then requiring the customer to “opt out” of the program, to decline the services and charges that were not requested by the customer themselves. Mr. Olsen requested the Board to vote “No” on Resolution 26-10.

A further comment was directed at Resolution 24-14, TN Soccer Academy Agreement (TSA). She continued with questions related to the projection of income that will be generated, versus the cost of the town in upholding its obligation to the TSA Agreement. Will the Town need to purchase equipment to properly maintain the fields (mowing, stripping, irrigation) and hire additional staff? It was requested that if the answers are not known to the Board at this time, postpone the vote on Resolution 26-14 for further review.

Karen Doyle – Maple Street – Ms. Doyle stated a workshop was scheduled for 6pm on March 12, 2026 during the February 19, 2026 meeting. When she arrived at the March 12th meeting, she found an empty building and parking lot. It was later that she discovered the meeting had been held March 11th. She suggested that public notice was in order, and future changes in meeting dates and times be better communicated.

Ms. Doyle then refers to the condition of Oakland's park playground equipment, stating families drive to Arlington so that their children can play. She asked if the new park would have decent playground equipment. Lastly, Ms. Doyle asked if there were any plans for Easter Egg Hunt this year.

8. Communications from the Mayor

Mayor Wiggins stated that concerns voiced during Citizen's Comments will be considered as the resolutions are presented to the Board.

Mayor Wiggins addressed Ms. Doyle's comments in stating it was nice to hear citizens speak publicly saying they want more things at the park faster. As for the meeting dates, Mayor Wiggins reported that all meetings are publicized in the same manner. He apologized to those who were inconvenienced related to the date change of March 2026 Work session and asked that the citizens check the Town's website for meeting times and dates.

9. Communication from the Aldermen

No comments

10. Department Head Reports

Blake Coker, Director of Wastewater Department, provided an update on the status of the Wastewater project, stating it is currently at its original deadline. He stated it would probably be May 2026, before startup.

Alderman Campbell requested Lorie Rice, Director of Finance, to approach the podium, to address accusations being made on the internet (Oakland Speaks, Facebook, Next-door) of a \$91,000 (ninety-one thousand dollars) shortage related to FY24 Audit year. Director Rice stated that "to my knowledge, there is no money missing." She further stated the auditors contracted to perform the FY25 audit are on site now and were asked to review the findings of the last audit, looking for anything that said there was money missing. The lead (FY25) auditor reported there was no such indication, however, the findings related to bank reconciliations, there were funds not properly reconciled. This finding pertained to the Town's State Insurance payment, which was recorded on the on the bank statement, but not in general ledger system.

When asked by Alderman Campbell if the TN Comptroller's Office had looked at this, Director Rice reported to the Board that she and Town Manager Ellis had a scheduled meeting (today) where the issue was addressed. According to Comptroller visitors, it was stated they have had no indication related to missing money, further stating if that were the case, the Comptroller's investigation team would have already sent here by now.

Town Manager Ellis reiterated Director Rice's comments; adding that people are rallying to have a forensic audit performed, which was also spoken to the Comptroller's representatives.

Mayor Wiggins, Alderman Campbell and Alderman LaBudde expressed their satisfaction in that there is no money missing based on this presentation by Director Rice and comments of Town Manager Ellis.

Alderman Austin asked Town Manager Ellis if the companies are billed for damages when main lines are hit? Mr. Ellis stated the companies are required to contact 8-1-1 before dig. The town has 3 days to locate and mark lines. In the event where the lines were improperly marked by town staff has been improperly located and marked, if a line is hit the town cannot charge the company; otherwise, they will be billed for damages. Mr. Ellis reported that the majority cannot be marked properly due to antiquated lines that do not have the tracing wire necessary to perform a proper locate.

Vice Mayor Cates asked Chase Weston, Director of Parks and Rec, if there are plans for an Oakland Easter Egg Hunt this year, which Director Weston said yes and that it had been posted. Vice Mayor then inquired if the Fireworks contract for the 4th of July Celebration had been nailed down and the location of the event, and again Director Weston stated yes, the contract is signed and the plans are to hold the event at the new park, at this time.

Town Attorney Minor announced an amendment to TCA 844-12, related to "Public Comments". The amendment now allows any matter that is germane to the local jurisdiction of the governing body to be an open item for public comments, regardless of the subject is on the agenda or not. This will become law, upon the governor's signature. Attorney Minor clarified the language pertaining to the time limit was not amended.

11. Town Manager's Report

Town Manager Ellis reported as receiving an email from Public Entity Partners stating the Town will receive a dividend on the Workers Comp portion of the Town's insurance in the amount of \$43,989.00.

12. Old Business: Ordinances Second and Final Reading w/ Public Hearings

A. Ordinance 26-02 – Amending The Town of Oakland Municipal Code Title 12, Electrical Code – GFCI Protection

Mayor Wiggins opened the floor to a Public Hearing. With no one approaching to speak, the Public Hearing was closed.

A motion to hear Ordinance 26-02 was made by Alderman Campbell and seconded by Alderman Bailey.

Mr. Ellis stated this also, is a requirement of the State of Tennessee that must be met prior to allowing Oakland's Code Enforcement Department to perform in-house electrical inspections.

A motion to approve the 2nd Reading of Ordinance 26-02 was made by Vice Mayor Cates. The motion was seconded by Alderman Campbell. All voted in favor, none opposed. The 2nd Reading of Ordinance 26-02 passed.

13. New Business: Ordinances First Reading

A. Ordinance 26-03 – Amending The Town of Oakland Municipal Code Title 18, Chapter 1, Section 18-111 - Billing Procedures and Rates

Removed from agenda (x2)

14. Consideration of Resolutions: Old Business

None presented

15. Consideration of Resolutions: New Business

A. Resolution 26-10 – Water Leak Insurance - Authorize Agreement

Alderman LaBudde made a motion to hear Resolution 26-10.

Ashely Wells and Ben Wensitt representing Water Leak Relief, LLC explained that water loss plays a part in rate increases, and this presented protection policy is a method of bridging that gap. It was explained that while ALL utility customers will be enrolled, the customers will have the ability to “Opt-Out” of the program at any time, making this a voluntary decision. To exercise the “Opt-Out” option, the customer will call the Water Leak Relief 800 number provided to them, a customer-service representative will read a brief paragraph stating that the customer understands by opting out of the program, the company will no longer make future bill adjustments; and the Town of Oakland will no longer make the adjustment as well. The call will be recorded and the record kept on file to avoid any disputes. He again reiterated this is a voluntary program – stating if someone contacts them, years from enrollment, stating they were not aware they were enrolled and wishes not to participate – a check will be processed for that customer in amount of the premiums they had been paying with no questions asked.

Ms. Wells described the process of filing a claim by first stating that the program covers anything caused by accident or nature from the meter on the customer’s side, (examples; a leaky flapper in toilet, a broken pipe under the sink). The customer will call the 800 number providing the account name, address and description of the problem. The company will reach out to the Town for the billing history. Once determined it’s a qualifying claim the company will calculate a 12-month billing average, which the customer will pay, and the company will be responsible for the additional portion billed amount for that month.

Alderman Bailey for clarity, stated this is coverage for both water and sewer, to which the representatives stated he was correct.

A motion was made by Vice Mayor Cates to approve Resolution 26-10. The motion was seconded by Alderman LaBudde. All voted in favor, none opposed. Resolution 26-10 passed.

B. Resolution 26-11 – 2026 Roadway Improvement Project – Award Contract

Alderman Campbell made a motion to hear Resolution 26-11.

Town Manager Ellis stated this project was put out for bids, with the bids opened on March 3rd. Staff recommend the bid be awarded to the low (and only) bidder, Fowler Paving Co. LLC in the amount of \$534,357.88 (five hundred thirty-four thousand, three hundred fifty-seven dollars and eighty-eight cents).

A motion was made by Alderman Austin to approve Resolution 26-11. The motion was seconded by Alderman LaBudde. All voted in favor, none opposed. Resolution 26-11 passed.

C. Resolution 26-12 – Market Vex, Webpage Management - 1 Year Contract Extension

Alderman LaBudde made a motion to hear Resolution 26-12.

Town Manager Ellis stated the current 24-month agreement is coming to term; however, it offers the option to enter an additional 1-year renewal, should both parties agree. Staff recommend exercising the 1-year contract extension clause.

A motion was made by Alderman LaBudde to approve Resolution 26-12. The motion was seconded by Alderman Austin. All voted in favor, none opposed. Resolution 26-12 passed.

D. Resolution 26-13 – Direct FX – Contract Renewal

Alderman LaBudde made a motion to hear Resolution 26-13.

Town Manager Ellis stated the current 12-month agreement will expire April 30, 2026. However, it offers the option of automatically renewing for successive 2-year terms. Staff recommend exercising the 2-year auto-renewal.

A motion was made by Vice Mayor Cates to approve Resolution 26-13. The motion was seconded by Alderman LaBudde. All voted in favor, none opposed. Resolution 26-13 passed.

E. Resolution 26-14 – Tennessee Soccer Academy, LLC – Authorize Agreement

Alderman LaBudde made a motion to hear Resolution 26-14.

Town Manager Ellis stated valid points were made during “Citizens’ Comments”, requesting the Board to give consideration of tabling this item until next meeting.

A motion was made by Vice Mayor Cates to table Resolution 26-14 until the next meeting. The motion was seconded by Alderman Campbell. All voted in favor, none opposed. Resolution 26-14 was tabled.

F. Resolution 26-15 – Authorizing Participation in PEP Matching Grant Program – Fire Department

Alderman Campbell made a motion to hear Resolution 26-15.

Town Manager Ellis stated the Oakland Fire Department has made application for a 50/50 matching grant offered by Public Entity Partners (PEP). Staff recommend acceptance of the \$2,000.00 (two-thousand dollars) grant from PEP. The funds will be used as partial reimbursement for previously purchased turn-out gear.

A motion was made by Vice Mayor Cates to approve Resolution 26-15. The motion was seconded by Alderman Campbell. All voted in favor, none opposed. Resolution 26-15 passed.

G. Resolution 26-16 – Appointment of Construction Board Members

Alderman Austin made a motion to hear Resolution 26-16.

Town Manager Ellis stated the following are noted qualified and willing to serve as appointed members of the Construction Board of Appeals; Mike Trexler, John Bigham, Tony Carter, Eric Huckaby and Walter Gill.

A motion was made by Alderman Austin to approve Resolution 26-16. The motion was seconded by Alderman LaBudde. All voted in favor, none opposed. Resolution 26-16 passed.

H. Resolution 26-17 – Shelby Electric, Traffic Signal Maintenance– 1 Year Contract Extension

Removed from agenda

I. Resolution 26-18 – Authorize Administration to Issue a Request for Proposals (RFP)for Managed Multifunction Copier Equipment and Services

Town Manager Ellis stated the current 36-month agreement will expire in June 2026. Staff recommend issuing an RFP to ensure that updated equipment is being provided, and that best suits the daily operations of each department.

A motion was made by Alderman LaBudde to approve Resolution 26-18. The motion was seconded by Alderman Campbell. All voted in favor, none opposed. Resolution 26-18 passed.

16. Other Items of Business:

A. Establish A Date and Time For Work Session

A work- session was not established.

17. Adjourn

Alderman Campbell made a motion to adjourn the meeting.

Date: March 19, 2026

Adrian Wiggins, Mayor

ATTEST:

K. Yvonne Bullard, Town Recorder

**PAGE
INTENTIONALLY
BLANK**

Mayor & Board of Aldermen –Work-Session @ 6:00PM

Minutes

- April 1, 2026

Present: Mayor Adrian Wiggins
Vice Mayor Cates
Aldermen Marilyn Austin, Dan Bailey, Harry Campbell, & LaBudde

1. Call to Order

Mayor Adrian Wiggins called the meeting to order.

2. Prayer & Pledge of Allegiance

Vice Mayor Cates

3. Others Present

Town Manager Ellis & Recorder Bullard & Oakland Department Directors: Lorie Rice, Ed Courton, Blake Coker, Chris Earle and Steve Walls. Supervisors: Kevin Perry and David Bouchard

4. Citizens Comments

None to speak

5. Items of Discussion

Budget Amendment
Police Department
Summer Adjustment Rate
Clay Street Improvement

Date: April 1, 2026

Adrian Wiggins, Mayor

K. Yvonne Bullard, Town Recorder

**PAGE
INTENTIONALLY
BLANK**

Mayor & Board of Aldermen –Special Call Meeting

Meeting Minutes

- April 1, 2026

Present: Mayor Adrian Wiggins
Vice Mayor Cates
Aldermen Austin, Bailey Campbell and LaBudde

1. Call to Order

Mayor Wiggins called the meeting to order.

2. Establish Quorum

All present

3. Prayer & Pledge of Allegiance

4. Citizen's Comments

None

5. Consideration to Enter An Executive Session

Alderman Bailey made a motion to enter an Executive Session. Alderman Campbell seconded the motion. All in favor, none opposed. The motion passed.

6. Reconvene Special Call Meeting

The Special Call meeting was reconvened by Mayor Wiggins.

A motion was made by Alderman Bailey to follow the advice of counsel. Alderman LaBudde seconded the motion. Four voted in favor, with Vice Mayor Cates opposing. The motion passed.

7. Adjourn

A motion to adjourn was made by Alderman Campbell.

Date: April 1, 2026

Adrian Wiggins, Mayor

K. Yvonne Bullard, Town Recorder

**PAGE
INTENTIONALLY
BLANK**

DRAFT

DRAFT

ORDINANCE 26-03

AN ORDINANCE AMENDING THE ADOPTED FISCAL YEAR 2026 BUDGET FOR THE TOWN OF OAKLAND, TENNESSEE GENERAL AND DRUG FUNDS (Amendment #1)

WHEREAS, Town Ordinance 25-05 adopts the Fiscal Year 2025-26 Annual Budget, All Funds; and

WHEREAS, it is now necessary to re-allocate and re-authorize certain expenditures, including capital expenditures, for the Fiscal Year 2026 Annual Budget; and

WHEREAS, it is now deemed in the public interest to amend the adopted Fiscal Year 2026 Budget to reflect the various changes to revenue and expenditures; and

WHEREAS, a Public Hearing on these changes was held on _____ following public notice published in the Fayette Falcon, a newspaper for general circulation.

NOW, THEREFORE, BE IT ORDAINED BY THE BOARD OF MAYOR AND ALDERMEN FOR THE TOWN OF OAKLAND, TENNESSEE AS FOLLOWS:

Section 1. That the Fiscal Year 2026 General Fund Budgeted Revenue be increased by \$288,518.12 (two hundred eighty-eight thousand, five hundred eighteen dollars and twelve cents) and the same is hereby amended:
Exhibit "A"

Section 2. That the Fiscal Year 2026 General Fund Budgeted Expense be increased by \$674,899.75 (six hundred seventy-four thousand, eight hundred ninety-nine dollars and seventy-five cents) and the same is hereby amended:
Exhibit "B"

Section 3. That (the Special Fund) Drug Fund Budgeted Revenue be increased by \$25,660. (twenty-five thousand, six-hundred and sixty dollars) and the same is hereby amended:
Exhibit "C"

Section 4. That (the Special Fund) Drug Fund Budgeted Expense be increased by \$23,500 (twenty-three thousand and five hundred dollars) and the same is hereby amended:
Exhibit "D"

Section 5. That this Ordinance shall take effect from and after its passage on second and final reading.

First Reading:
Public Hearing:
Second Reading:

DRAFT

Attest:

Adrian Wiggins, Mayor

K. Yvonne Bullard, Town Recorder

DRAFT

DRAFT

EXHIBIT "A" GENERAL FUND – 110 REVENUE

Department	Fund	Code	Revenue Description	FY 2026 Original Budget	FY 2026 Change In Budget	FY 2026 Amended Budget	
Admin Taxes	General -110	31110	Real And Personal Property Tax	3,067,152	0	3,067,152	
	General -110	31200	Property Taxes (Prior Years)	30,000	(4,118)	25,882	
	General -110	31300	Int, Penalty, And Court Cost On Prop	9,000	(2,279)	6,721	
	General -110	31510	Ad Valorem	31,000	9,436	40,436	
	General -110	31610	Local Sales Tax - Co. Trustee	2,800,000	102,643	2,902,643	
	General -110	31710	Wholesale Beer Tax	250,000	(42,208)	207,792	
	General -110	31720	Wholesale Liquor Tax	115,000	(21,174)	93,826	
	General -110	31910	Franchise Taxes	39,000	(20,763)	18,237	
Admin Licenses & Permits	General -110	31911	Natural Gas Franchise Tax - Somerville	57,000	(2,177)	54,823	
	General -110	32200	Alcoholic Beverage Licenses	500	(125)	375	
	General -110	32300	Beer Privilege Tax	9,500	5,275	14,775	
	General -110	32610	Building Permits	200,000	(9,608)	190,392	
	General -110	32612	Inspection/Reinspection Fees	80,000	(5,638)	74,363	
	General -110	32613	Permit Processing Fee	4,000	5,548	9,548	
	General -110	32614	Subdivision Dev Inspection Fees	20,000	5,500	25,500	
	General -110	32616	Subdivision Dev Park Fee	10,000	10,625	20,625	
	General -110	32630	Plumbing Permits	40,000	7,928	47,928	
	General -110	32650	Excavating Permits	8,000	(1,303)	6,698	
	General -110	32660	Zoning/P lanning Permits	30,000	29,418	59,418	
	General -110	32670	Fence Permits	3,000	4,463	7,463	
	General -110	32680	Mechanical Permits	40,000	26,881	66,881	
	General -110	32910	Sign Permits	1,000	(1,000)	0	
	General -110	32920	Solicitation Permits	3,500	(2,938)	563	
	General -110	32960	Fireworks Permits	7,500	(7,500)	0	
	General -110	32992	Business Permits	250	(250)	0	
	Admin Charges for Services	General -110	34131	Administrative Services	36,000	0	36,000
		General -110	34141	Duplication & Printing	50	121	171
		General -110	34220	Special Fire Protection/Fire	50,000	70,000	120,000
General -110		34740	Park & Recreation Sr. Activity Fees	1,000	(1,000)	0	
General -110		34746	Parks & Recreation Athletics	7,500	700	8,200	
General -110		34751	Town Facility - Rental Fees	10,000	(8,820)	1,180	
Admin Intergovernmental	General -110	33195	Grant Proceeds - GH50	3,000	22,651	25,651	
	General -110	33320	TVA-In Lieu of Taxes	110,000	(10,000)	100,000	
	General -110	33490	Other State Grants	0	30,118	30,118	
	General -110	33491	TDEC Recreation Grant 50% Match	2,500,000	0	2,500,000	
	General -110	33510	State Sales Tax	1,130,000	46,249	1,176,249	
	General -110	33512	State Local Option -Park Project	1,200,000	87,805	1,287,805	
	General -110	33530	State Beer Tax	4,500	(1,587)	2,913	
	General -110	33540	State Alcohol Tax	18,000	(320)	17,680	
	General -110	33552	State-City Street & Trans. Petro	16,000	247	16,247	
	General -110	33558	State EV Fees Transp. Modernization	2,000	2,982	4,982	
	General -110	33593	Corporate Excise Tax	14,500	0	14,500	
	General -110	33594	State Telecommunications Tax	700	(51)	649	
	General -110	33595	State Sports Betting Revenue	15,000	5,000	20,000	
	General -110	33700	Contracts- Local Govts - FCT Fire Calls	36,000	0	36,000	
	General -110	33710	Fayette County Fire Calls	40,000	0	40,000	
	Admin Other Revenue	General -110	36140	Interest Income - Checking	300,000	(105,227)	194,773
General -110		36152	Interest FCB Park Project	35,000	64,469	99,469	
General -110		36155	Interest Income - Payroll	1,000	300	1,300	
General -110		36350	Insurance Recoveries	8,000	(7,200)	800	
General -110		36990	Miscellaneous Refund	1,000	6,482	7,482	
General -110		33196	Grant Proceeds - PEP Cybersecurity	1,000	6,200	7,200	
Police Revenue	General -110	35110	City Court Fines And Costs	650,000	2,964	652,964	
	General -110	35113	E-Citations Revenue - Police	1,000	(1,000)	0	
	General -110	35160	Court Fines And Costs - Higher Court	1,500	(1,500)	0	
	General -110	35162	Circuit Court Fees	1,000	(1,000)	0	
	General -110	35163	General Sessions Court Fees	5,000	(5,000)	0	
	General -110	35165	FC Juvenile Court	200	(200)	0	
	General -110	35190	State of TN - Police Revenue	500	(500)	0	
	General -110	36000	Other Revenue - Suspended License	1,000,000	(1,000)	0	
	Total Original Budget				13,055,852		
Total REV Change in Budget					288,518		
Total Amended Budget						13,344,370	

DRAFT

DRAFT

EXHIBIT "B"		GENERAL FUND – 110 EXPENSE				
Department	Fund	Code	Expense Description	FY 2026	FY 2026	FY 2026
				Original	Change In	Amended
				Budget	Budget	Budget
Admin	General -110 - 41000	245	Telephone & Other Communications	23,000	2,876	25,876
	General -110 - 41000	253	Accounting and Auditing	64,000	55,498	119,498
	General -110 - 41000	266	Repair and Maintenance - Buildings	25,000	10,000	35,000
	General -110 - 41000	254	Architectural/Engineering - Town Hall	64,000	50,000	114,000
	General -110 - 41000	259	Other Professional Svcs - Salary Study	1,000	24,350	25,350
Industrial Dev. Board	General -110 - 47220	252	Legal Fees	0	10,000	10,000
Police	General -110 42100	245	Telephone & Other Communications	21,500	3,241	24,741
	General -110 42100	326	Uniforms	20,000	11,000	31,000
	General -110 42100	511	General Liability	142,000	7,065	149,065
Fire	General -110 42200	200	Contracted Services	20,000	10,000	30,000
	General -110 42200	245	Telephone & Other Communications	14,000	2,373	16,373
	General -110 42200	511	General Liability	23,725	8,882	32,607
Planning	General -110 41700	530	Office Rent	10,200	2,850	13,050
Building Codes	General -110 41900	200	Contracted Services	10,000	7,737	17,737
	General -110 41900	530	Office Rent	10,200	2,850	13,050
Public Works	General -110 43000	511	General Liability	11,567	1,964	13,531
Parks & Rec	General -110 44400	261	Repair & Maintenance - Vehicles	500	1,800	2,300
	General -110 44400	290	Other Contractual Services	0	2,685	2,685
	General -110 44400	900	Park Capital Project	4,207,574	459,730	4,667,304
Total Original Budget				4,668,266		
Total Exp Change in Budget					674,900	
Total Amended Budget						5,343,166

EXHIBIT "C"		SPECIAL FUND - DRUG FUND – 127 REVENUE				
Department	Fund	Code	Revenue Description	FY 2026	FY 2026	FY 2026
				Original	Change In	Amended
				Budget	Budget	Budget
Drug Fund	Drug - 127	35140	Drug Related Fines	140	15,360	15,500
	Drug - 127	35142	Genneral Sessions - Drug Fines	0	5,000	5,000
	Drug - 127	36140	Interest Income Checking	0	5,300	5,300
Building Codes				140	25,800	
Total Original Budget				140		
Total REV Change in Budget					25,660	
Total Amended Budget						25,800

EXHIBIT "D"		SPECIAL FUND - DRUG FUND – 127 EXPENSE				
Department	Fund	Code	Expense Description	FY 2026	FY 2026	FY 2026
				Original	Change In	Amended
				Budget	Budget	Budget
Drug Fund	Drug - 127-42129	922	Operational -Drug K-9	0	16,000	16,000
	Drug - 127-42129	312	Small Items of Equipment	0	7,500	7,500
SPECIAL FUND - Drug Fund				0	23,500	23,500
Total Original Budget				0		
Total Exp Change in Budget					23,500	
Total Amended Budget						23,500

DRAFT

**PAGE
INTENTIONALLY
BLANK**

Resolution 26-19

**A RESOLUTION OF THE TOWN OF OAKLAND, TENNESSEE AUTHORIZING A
PROFESSIONAL SERVICES AGREEMENT WITH A2H ENGINEERING FOR
MUNICIPAL COMPLEX PRE-DESIGN SERVICES**

WHEREAS, The Town of Oakland Mayor and Board of Aldermen recognize the need and desires to build a new municipal complex; and,

WHEREAS, A2H Engineers, Architects & Planners, has submitted to the Town of Oakland a proposed Professional Services Agreement related to the design and consulting of the project; and

WHEREAS, it is the opinion of the Town's Board of Mayor and Aldermen that the best interest of the Town will be served by entering into the agreement with A2H Engineers, Architects & Planners for Pre-Design Services.

NOW, THEREFORE, BE IT RESOLVED BY THE BOARD OF MAYOR AND ALDERMEN OF THE TOWN OF OAKLAND, TENNESSEE:

SECTION 1: The Mayor is authorized to execute the Agreement between the Town of Oakland and A2H Engineers, Architects & Planners, for the services described in Agreement #26167 attached and incorporated herein as Exhibit A, detailing a total investment cost of \$59,760.00 for Basic Scope of Service plus reimbursable fees. Additional services not included in the Basic Scope shall be billed in accordance with the hourly rate schedule detailed on page 3, Section VI: Additional Services.

A motion was made by ___ to approve Resolution 26-19. The motion was seconded by __. ___ voted in favor, ___ opposed. Resolution 26-19 ___.

Done by order of the Board of Mayor and Aldermen of the Town of Oakland, Tennessee this ___ day of ___, 2026.

ATTEST:

Adrian Wiggins, Mayor

K. Yvonne Bullard, Town Recorder



ENGINEERS ARCHITECTS PLANNERS

April 9, 2026

Harvey Ellis
Town Manager
Town of Oakland, TN
170 Doss Circle
Oakland, TN 38060

COPY

Re: Town of Oakland, TN
Municipal Complex
Pre-design Services
Oakland, TN
A2H # 26167

Dear Harvey,

A2H is pleased to submit our Contract for design and consulting related services for this project. As an integrated Engineering, Architectural and Planning firm, A2H offers all services required to successfully complete this project. If you agree with the terms as outlined within the enclosed Contract, please acknowledge your acceptance by signing and dating the Contract and initialing the Terms and Conditions in the spaces indicated and return one executed Contract to our office.

If selected, please note that Thomas Dodd will serve as Project Manager for this project and will be your contact person in our office. If you have any questions or require additional information, please do not hesitate to contact either me or Thomas at any time.

Thank you for giving us the opportunity to submit this Contract.

Sincerely,
A2H, INC.

Logan E. Meeks, PE
President | Principal

Thomas Dodd, AIA
Senior Architect | Project Manager



ENGINEERS ARCHITECTS PLANNERS

April 9, 2026

Harvey Ellis
Town Manager
Town of Oakland, TN
170 Doss Circle
Oakland, TN 38060

COPY

Re: Town of Oakland, TN
Municipal Complex
Pre-design Services
Oakland, TN

A2H # 26167

Dear Harvey,

A2H is pleased to respond to your request for Professional Services on the above referenced project. By way of this Contract, we are enclosing our understanding of the scope of work required for the project and shall perform the Professional Services upon the terms and conditions set forth in this letter.

I. The following represents our understanding of the project description:

A2H will be responsible for professional design and consulting services necessary for the Municipal Complex proposed in Oakland, TN with a precise location to be determined.

II. It is our understanding that the Basic Scope of Services includes:

A2H will provide the following as part of our Basic Scope of Services, working closely with Town of Oakland, TN to provide these services in support of the project:

- Project Management
- Planning
- Land Surveying
- Civil Engineering
- Landscape Architecture
- Architecture
- Structural Engineering
- Mechanical Engineering
- Plumbing Engineering
- Fire Protection Engineering
- Electrical Engineering

The phases described below represent our understanding of the project requirements as indicated by the Client:

Programming & Site Selection Assistance

- A. A2H will meet with the Town to develop the Project Space Program for the functions of this new Municipal Complex facility. The Programming Session will identify required spaces, sizes, adjacencies, department organization, and establish Space Standards for the development of this new facility. The effort for this is anticipated to be one meeting with the town representatives, including a small group of end users, to determine the needs and wants of the facility.
- B. A2H will provide high-level site selection assistance to support the Town in identifying and evaluating potential properties for the proposed Municipal Complex. This effort will include defining site selection criteria based on operational needs identified during programming, including but not limited to access and circulation requirements, site size, utility availability, zoning compatibility, visibility, parking capacity, public accessibility, and potential environmental or topographic constraints. A2H will prepare a summary of recommended site characteristics and provide conceptual-level input to assist the Town in comparing candidate sites. Detailed due diligence, surveying, geotechnical investigation, and formal entitlement services are not included in this phase and would be addressed under a subsequent scope upon identification of a preferred site.

Concept Design

- A. A Concept Site Plan and Floor Plan will be developed to illustrate the Program requirements for the project and establish how they work individually and together as one complex and best fit on the site. The effort for this is anticipated to be one meeting with the town representatives, including a small group of end users, to present a draft version of the written program.
- B. Concept Elevations will be created to define the building and architectural style and details.
- C. An exterior 3-D perspective rendering will be provided with this phase.
- D. Engineering narratives of building systems will be provided with this phase.
- E. A2H will assist the Town of Oakland in establishing a budget for this project based on the approved concept design.

III. Exclusions from our Basic Scope of Services are as follows:

Services not set forth above as Basic Scope of Services in this Contract are excluded from the scope of our work and can be provided as Additional Services upon request. We assume no responsibility to perform such services excluded, including but not limited to:

- A. Services required because of significant changes in the project, including changes in size, quality, complexity, schedule or methods of bidding.
- B. Phase I and/or Phase II Environmental Site Assessment.
- C. Geotechnical Engineering services for appropriate geotechnical engineering design criteria for earth-related phases.
- D. Land Surveying services, including but not limited to boundary surveys, topographic surveys, ALTA/NSPS surveys, subdivision plats, easement descriptions, and construction staking.
- E. Wetlands delineations, stream determinations, jurisdictional determinations, permitting, and related coordination with federal, state, or local regulatory agencies, including but not limited to U.S. Army Corps of Engineers or state environmental agencies.
- F. Construction Cost Estimating services.

IV. Our proposed schedule of deliverables for the above referenced Basic Scope of Services is as follows:

A. A2H will provide the Client with a schedule for project deliverables within two weeks of the Notice To Proceed.

V. Our proposed compensation for the above referenced Basic Scope of Services is as follows:

Programming & Site Selection Assistance	\$	9,760.00
Concept Design	\$	49,500.00
Compensation for Basic Scope of Services	\$	59,260.00
Reimbursable Expense Fee (Courier Service, Mileage, and Printing)	\$	500.00

VI. Additional Services:

Additional services shall consist of all services not included in the Basic Services as set forth above. No work will be performed beyond the services noted above without an express written agreement between A2H and Town of Oakland, TN. Additional Services will be billed either on an hourly basis in accordance with the hourly rate schedule contained herein, or a negotiated fixed fee based on the scope of additional services requested. The A2H Hourly Rate Schedule is as follows:

STAFF MEMBER	LEVEL I	LEVEL II	LEVEL III
Principal	\$ 210.00	\$ 225.00	\$ 240.00
Associate Principal	\$ 165.00	\$ 180.00	\$ 195.00
Project Manager	\$ 140.00	\$ 160.00	\$ 180.00
Project Coordinator	\$ 100.00	\$ 110.00	\$ 120.00
Architect	\$ 145.00	\$ 165.00	\$ 185.00
Engineer	\$ 140.00	\$ 160.00	\$ 180.00
Senior Designer	\$ 125.00	\$ 145.00	\$ 165.00
Interior Designer	\$ 110.00	\$ 130.00	\$ 150.00
Planner	\$ 110.00	\$ 130.00	\$ 150.00
Designer	\$ 100.00	\$ 110.00	\$ 120.00
BIM/CAD Technician	\$ 85.00	\$ 100.00	\$ 115.00
Administrator	\$ 75.00	\$ 85.00	\$ 100.00

This Contract and the Terms and Conditions attached hereto and incorporated herein satisfactorily set forth your understanding and the agreement between us. This Contract will be open for acceptance for 60 calendar days. We certainly look forward to collaborating with you on this project and thank you for giving us the opportunity to submit this Contract.

If you have any questions, please call.

Sincerely,
A2H, INC.



Logan E. Meeks, PE
President | Principal

Attachment: Terms and Conditions

This Contract entered into as of the day and year written below.

AGENT FOR: TOWN OF OAKLAND, TN

ACCEPTED BY: _____

DATE: _____

TITLE: _____

COPY

COPY

TERMS AND CONDITIONS

1. The parties agree that **TOWN OF OAKLAND, TN** is solely responsible for payment in accordance with the following terms. A2H, Inc. (hereinafter sometimes "the Consultant") shall submit monthly invoices for work in progress. Payment shall be due upon receipt. Invoices more than 30 days old will be subject to a finance charge of 1.5% per month. The Consultant shall have the right to cease work if payment is not received within 45 days of each invoice. In addition, **TOWN OF OAKLAND, TN** agrees to pay any and all legal expenses and other costs incurred in the collection of any overdue amount.
2. **TOWN OF OAKLAND, TN** shall reimburse the Consultant all expenses incurred for courier services, (e.g., Federal Express, United Parcel Service, etc.) mileage, travel, and printing. Mileage shall be reimbursed at the current IRS standard mileage rate. Reimbursable Expenses Fee shall be billed as a flat rate per Section V of the contract.
3. In the event of any litigation arising from or related to this Contract or the services provided under this Contract, the "prevailing party" shall be entitled to recover from the "non-prevailing party" all reasonable legal expenses and attorney's fees incurred in such litigation. For the purposes of this provision, a party asserting a claim shall be considered the "prevailing party" only if it recovers 50% or more of the amount claimed. If it does not, the claimant shall be the "non-prevailing party."
4. **TOWN OF OAKLAND, TN** shall make no claim for professional negligence, either directly or by way of a cross complaint against the Consultant unless **TOWN OF OAKLAND, TN** has first provided the Consultant with a written certification executed by an independent Consultant currently practicing in the same discipline as the Consultant and licensed in the State of the project. This certification shall: a) contain the name and license number of the certifier; b) specify the acts or omissions that the certifier contends are not in conformance with the standard of care for a consultant performing professional services under similar circumstances; and c) state in detail the basis for the certifier's opinion that such acts or omissions do not conform to the standard of care. This certification shall be provided to the Consultant not less than thirty (30) calendar days prior to the presentation of any claim or the institution of any arbitration or judicial proceeding. This Certificate of Merit clause takes precedence over any existing state law in force at the time of the claim or demand for arbitration.
5. The Consultant shall commence services within seven (7) days of receiving executed acceptance of this Contract from **TOWN OF OAKLAND, TN** along with all project information needed to commence services. The Consultant shall perform the work with due diligence commensurate with sound professional practice.
6. The Consultant shall be responsible for the items listed in the scope of services only. Responsibility for any other items not specifically mentioned in the scope of services or shown on the drawings produced by the Consultant shall be borne by **TOWN OF OAKLAND, TN**.
7. Notwithstanding any other provision of this Contract or the parties' contract, in providing services under this Contract, the Consultant shall endeavor to perform in a manner consistent with that degree of care and skill ordinarily exercised by members of the same profession currently practicing under similar circumstances.
8. **TOWN OF OAKLAND, TN** acknowledges the reports, plans, specifications, field data and notes and all other documents prepared by the Consultant, including all documents on electronic media, are instruments of professional service that shall remain the property of the Consultant. **TOWN OF OAKLAND, TN** shall not reuse, make, or permit to be made, any modifications to the plans and specifications without the prior written authorization of the Consultant. **TOWN OF OAKLAND, TN** agrees, to the fullest extent permitted by law, to indemnify, release, and hold harmless the Consultant from any claims arising from any unauthorized reuse or modification of the plans and specifications.
9. The Consultant makes no warranties, either expressed or implied, of merchantability, fitness for use for any particular purpose, or of any other nature or type. In no event shall the Consultant be liable to **TOWN OF OAKLAND, TN** for any loss of profit, loss of use, or any other consequential damages.
10. If there are protracted delays for reasons beyond the control of the Consultant, the Consultant's compensation shall be equitably adjusted.
11. Neither party to this Contract shall transfer, sublet or assign any rights under or interest in this Contract (including but not limited to monies that may be due) without the prior written consent of the other party. The Consultant shall be permitted to subcontract portions of the professional services required under this Contract to properly qualified subconsultants.
12. This Contract may be terminated by either party upon seven days' written notice in the event of substantial failure by the other party to perform in accordance with the terms hereof through no fault of the terminating party. In the event of termination, by either party, the Consultant shall be paid for all services rendered and all reimbursable expenses up to and through the date of termination.
13. The fees charged by the Consultant have been structured in part in reliance upon the agreement and covenant of the **TOWN OF OAKLAND, TN** that the liability of the Consultant for any defects in the services provided hereunder shall be limited to the total fee the Consultant charged for services rendered on the project.
14. In the event of defects in the services performed by the Consultant for which the Consultant is liable to **TOWN OF OAKLAND, TN**, the measure of damages may include the cost of remediation work but shall not include the cost of work that adds value to the project for which **TOWN OF OAKLAND, TN** would have been obligated to pay if the services had not been defective.

COPY

Initials

Date

15. Any and all suits for any breach of this Contract shall be instituted and maintained in any Court of competent jurisdiction in Fayette County, Tennessee and both parties expressly consent to the jurisdiction of such Court.
16. If any portion of this Contract shall in any way become violative or prohibited by or under applicable laws, that provision or part hereof shall be ineffective and void to the extent of such violation or prohibition without invalidating any of the remaining provisions of this Contract.
17. In the event **TOWN OF OAKLAND, TN** consents to, allows, authorizes or approves of changes to any plans, specifications or other documents, and these changes are not approved in writing by the Consultant, **TOWN OF OAKLAND, TN** acknowledges that such changes, and the results thereof, are not the responsibility of the Consultant. Therefore, **TOWN OF OAKLAND, TN** agrees to release the Consultant from any liability arising from such changes. In addition, **TOWN OF OAKLAND, TN** agrees, to the fullest extent permitted by law, to indemnify and hold the Consultant harmless from any damage, liability or cost, including reasonable attorneys' fees and costs of defense, arising from such changes.
18. Original signed, sealed reproducible documents are the actual Contract Documents and any electronic copies provided to the Client are the Client's convenience. In the event there is a discrepancy between the original signed, sealed documents and the electronic copy, the original signed, sealed reproducible documents shall take precedence.
19. This Contract represents the entire understanding between **TOWN OF OAKLAND, TN** and A2H, Inc. in the respect to the project and may be modified only by a writing signed by both parties.
20. If in the event that an executed copy of this Contract is not returned to our office, but payment is received for services rendered during the course of the project, the parties agree that these terms and conditions shall be binding upon the parties.

A red stamp consisting of a small square containing the letter 'C' followed by the word 'COPY' in a bold, sans-serif font, tilted at an angle.

Initials

Date

**PAGE
INTENTIONALLY
BLANK**

Resolution Number 26-20

**A RESOLUTION OF THE TOWN OF OAKLAND, TENNESSEE TO AUTHORIZE
PURCHASE OF A RAX-300 ROBOTIC INSPECTION CAMERA SYTEM**

WHEREAS, the Town of Oakland is responsible for inspecting various pipelines throughout the Town; and,

WHEREAS, a robotic inspection camera will be beneficial in performing repairs, cleaning and maintenance of sewer lines and stormwater infrastructure; and,

WHEREAS, the Town's adopted Fiscal Year 2025-2026 Annual Budget includes funds for the purchase of this specialized equipment; and,

WHEREAS, Sourcewell, a national co-operative purchasing program for state and local governments has bid the needed equipment and based upon those bids, said equipment is available and can be competitively purchased through a local vendor; and,

WHEREAS, the Town Manager and Town Attorney have now determined that the purchase by the Town of a robotic inspection camera can legally be made through Sourcewell without having to submit the purchase to a public bidding procedure.

NOW, THEREFORE, BE IT RESOLVED BY THE BOARD OF MAYOR AND ALDERMEN OF THE TOWN OF OAKLAND, TENNESSEE:

SECTION 1: That the purchase of a RAX-300 Robotic Inspection Camera from Sansom Equipment Company, Shelbyville, TN., in the total amount of \$149,998.94 (one-hundred forty-nine thousand, nine hundred and ninety-eight dollars and 94 cents) which is authorized through Source-well is hereby approved.

SECTION 2: That the Board of Mayor and Aldermen approve this purchase based upon funds allocated in the Fiscal Year 2025–2026 Budget, Public Works Dept. and Wastewater Dept. Capital Equipment.

A motion was made by ___ to approve Resolution 26-20. The motion was seconded by __. ___ voted in favor, _ opposed. Resolution 26-20 ___.

Done by order of the Board of Mayor and Aldermen of the Town of Oakland, Tennessee this ___ day of ___, 2026.

Adrian Wiggins, Mayor

ATTEST:

K. Yvonne Bullard, Town Recorder

ROVVER X

AGILE, INTELLIGENT
SEWER INSPECTION
SYSTEM



ENVIROSIGHT

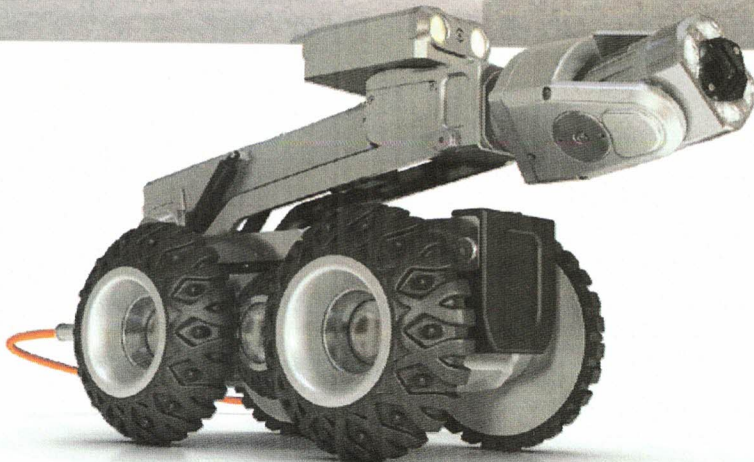

 ENVIROSIGHT

GAIN DEEPER INSIGHT

When you open a manhole, be ready to get the full picture.

With unmatched power and agility, ROVVER X delivers the insight you need to make critical maintenance decisions. It offers industry-leading productivity with a simple interface, advanced capabilities and support for digital workflows.

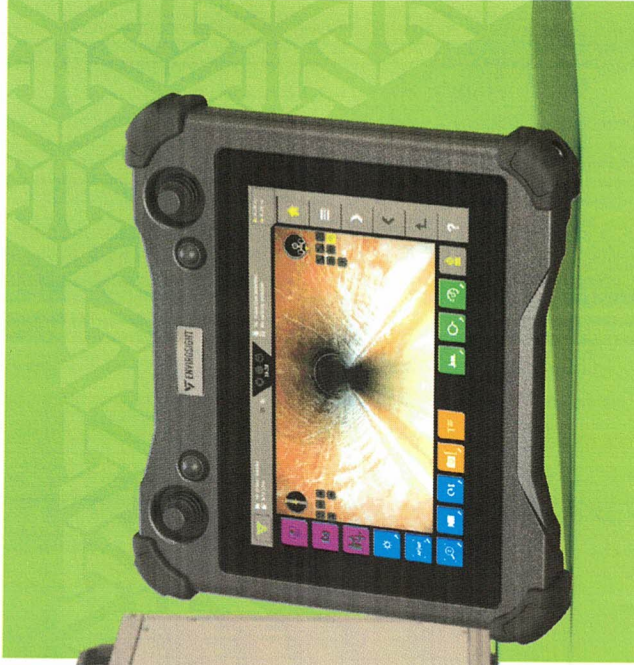
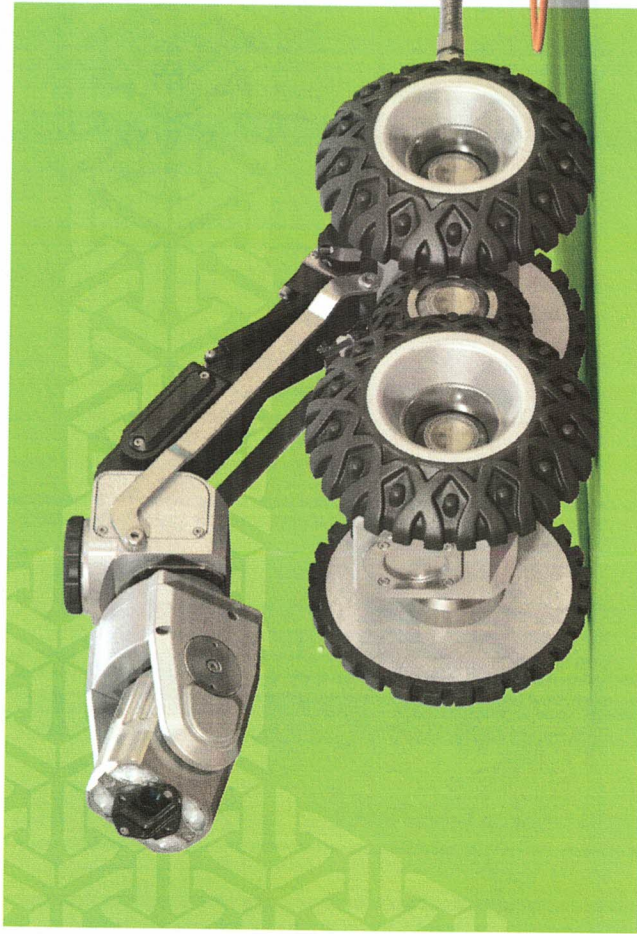

SIMPLE

Cut out complexity for your crew with technology that's easy to learn and use, a responsive support team, and a regional service network that delivers rapid turnaround.



RELIABLE

Stay on schedule and within budget with ROVVER X's industry-low downtime and cost-of-ownership. Not only is it built to endure punishment, its intuitive design lets you perform routine maintenance right in the field.



ADAPTABLE

Tackle any inspection challenge. ROVVER X accessories and wheels swap in seconds to fit any pipe size, material and condition. And when the job calls for specialized capabilities, easily add lateral launch, laser profiling, side scanning and more.



AGILE

Power past obstacles that sideline other crawlers. With steerable six-wheel drive, ROVVER X avoids obstructions and climbs over debris and offsets. An array of onboard sensors helps you avoid hazards.



SMART

Access every capability from a single interface -- operate the crawler, record video, overlay text, log observations, measure defects and create reports. Inspection data streams securely to the cloud, and the system auto-updates to the latest features.

ADAPTABLE

ROVVER X is the only crawler system that lets you change wheels and accessories rapidly without tools. Achieve new levels of productivity, and confidently handle any combination of pipe size, material and condition.

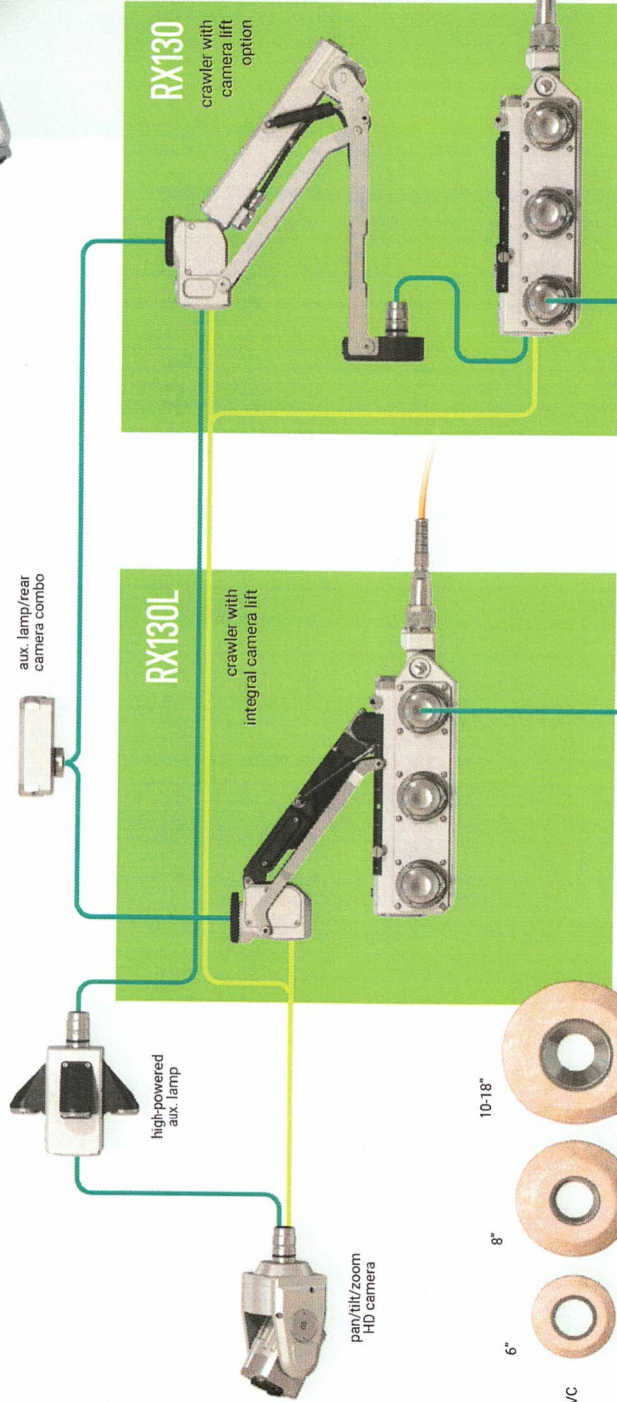
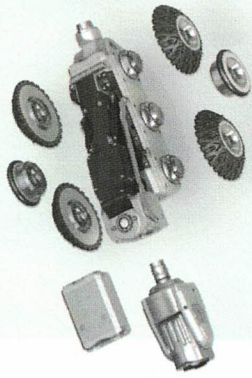

Scan to see ROVVER X's quick-change capabilities in action.

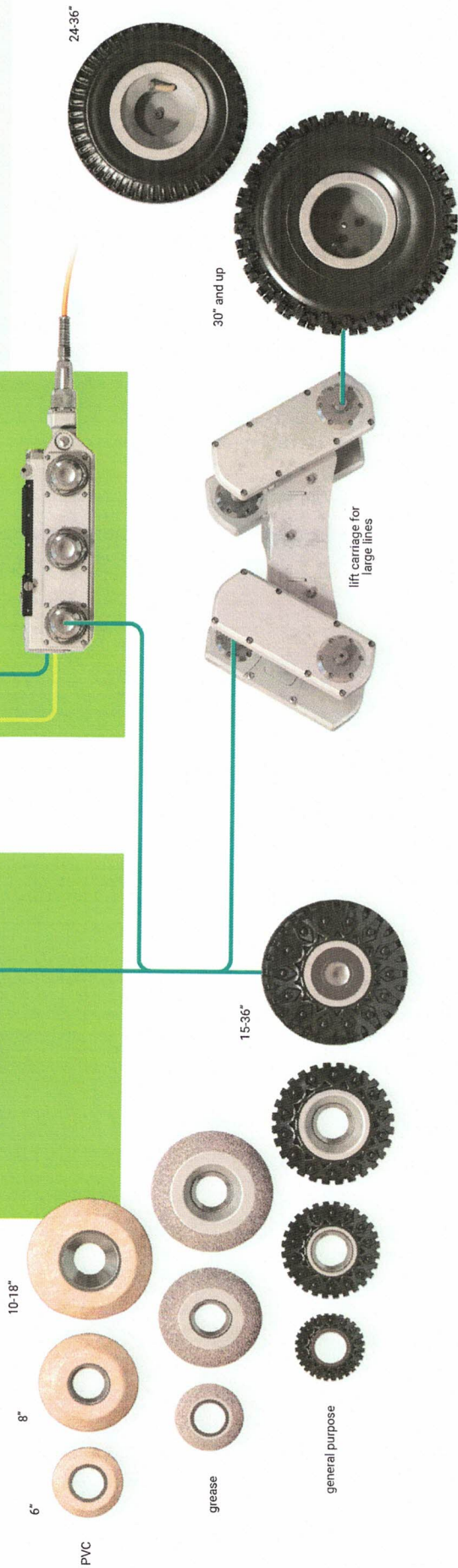

SMART

Simple to learn yet powerfully capable, ROVER X's touchscreen controls support your entire inspection workflow. And with built-in Wi-Fi, you can share inspections online and keep your ROVER X system updated with the latest features.

FLEXSPECTION

Sometimes you need maximum detail, sometimes you need minimum file size—and sometimes you need a compromise. With Flexspec, the choice is yours.

SD HD 720P HD 1080P

NEED LESS?

This remote control puts all major crawler and reel functions in the palm of your hand, and it comes standard with every ROVER X system.



camera joystick

crawler joystick

Flexspecation only available on VC500 HD controller.

NEED EVEN MORE?

For maximum productivity, this optional desktop command center offers precision control, full QWERTY keyboard, and ergonomic comfort.



OPERATE

Control every ROVER X function using twin multi-function joysticks, intuitive touchscreen controls and real-time feedback. Onscreen notifications help warn against operating hazards.

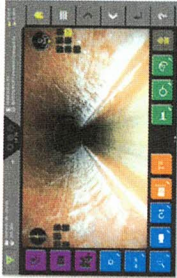

OVERLAY TEXT

With drag-and-drop simplicity, create an overlay that has static text, live data, observation details and your logo. Customize text position, color and background to your preference.

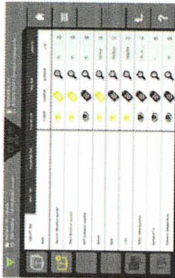

MEASURE DEFECTS

Powerful measurement tools let you size up cracks, water level, pipe diameter, wall features, bend angles, inclination and much more.



ENTER OBSERVATIONS

Create an inspection, then log observations with help from onboard defect catalogs, including PACP and WRC.

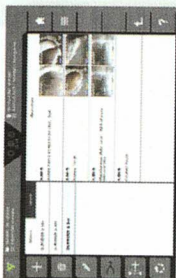

CREATE REPORTS

Generate PDF reports from completed inspections, then deliver them via USB drive.



CONNECTED

Wirelessly upload your inspections directly to WinCan Web, the cloud platform for sewer inspection data. Review, edit, analyze and map inspection data online, and securely share results with your entire team.

WinCan
Web

Scan to set up your free WinCan Web trial account.



CAPABLE

When you choose ROVVER X, you're prioritizing productivity. Advanced features ensure your team collects crystal clear footage and actionable data from any line with minimal disruptions.



The rugged **ROVVER X cable** boasts a 1000-lb break strength. And with just 6 conductors, it's easy to field-terminate

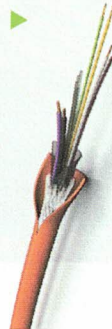

Available in 984' and 1640' versions, the **ROVVER X reel** automatically feeds cable so the crawler doesn't have to pull it off the reel. This extends travel range and reduces crawler wear-and-tear.



SCALABLE

Once you own the ROVVER X platform, the sky is the limit. Specialty crawlers and attachments give you plug-and-play capability, so you can meet any inspection challenge.

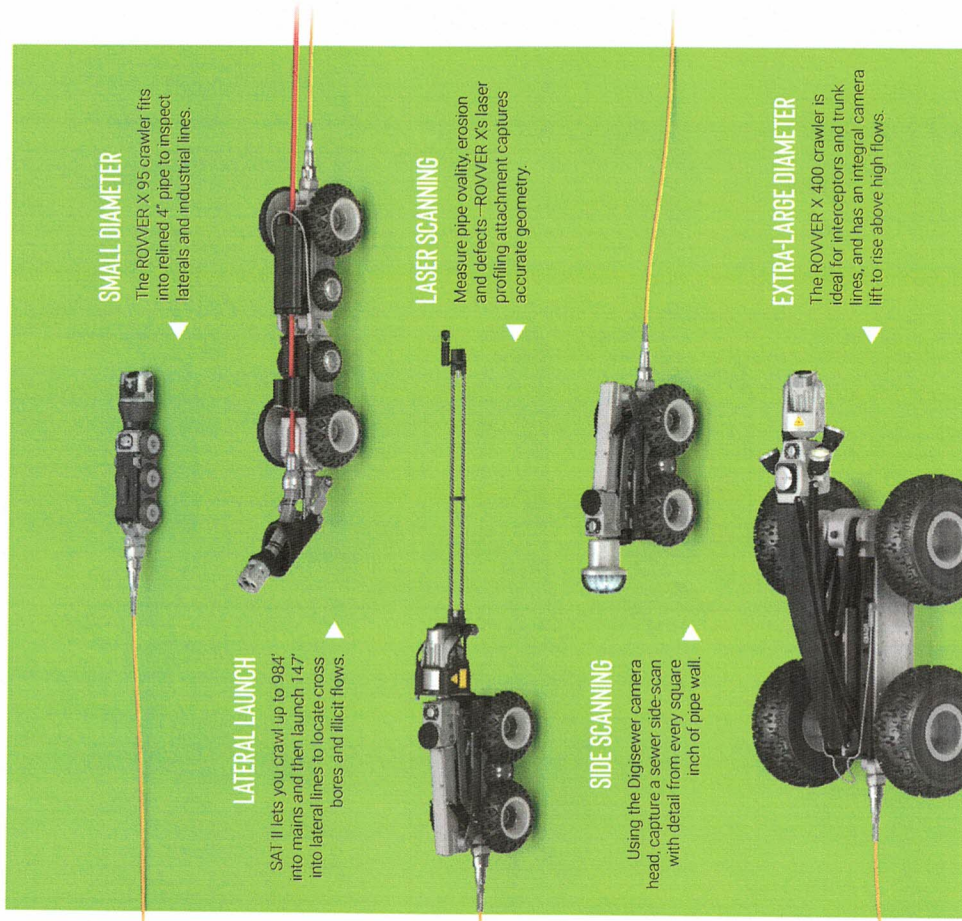

SMALL DIAMETER

The ROVVER X 95 crawler fits into reamed 4" pipe to inspect laterals and industrial lines.

LATERAL LAUNCH

SAT II lets you crawl up to 984' into mains and then launch 147' into lateral lines to locate cross bores and illicit flows.

LASER SCANNING

Measure pipe ovality, erosion and defects—ROVVER X's laser profiling attachment captures accurate geometry.

SIDE SCANNING

Using the Digisewer camera head, capture a sewer side-scan with detail from every square inch of pipe wall.

EXTRA-LARGE DIAMETER

The ROVVER X 400 crawler is ideal for interceptors and trunk lines, and has an integral camera lift to rise above high flows.

Consult sales representative for ideal setup and compatibility.

MOBILE

Stay safe, productive and comfortable while deploying your ROVVER X in the field. EnviroSight-built vehicles protect your crew and offer full amenities—ensuring your equipment, tools, and safety gear are within easy reach.



PANEL VANS

Fit into alleys and other tight spaces while deploying ROVVER X or lateral launch. Choose among Sprinter, Transit and ProMaster options, with power from an inverter or vehicle PTO.

Power options include generator (gas or diesel), inverter with battery, or engine PTO.

BOX TRUCKS

Get maximum elbow room, plus extra capacity for lateral launch systems, generator power sources and cranes.



TRAILERS

Gain flexibility when inspection is part time or when inspection equipment must be shared between crews.



ENCLOSURES

Deploy an EnviroSight Outpost when you need access to easements and other remote workites using a pickup or ATV.



TRUSTED

Standing behind ROVVER X is a team with decades of experience helping sewer professionals succeed. We've built the industry's largest network of regional support and service locations—so wherever the job takes you, help is never far.



Don't take our word for it. Some of the largest cities and contractors trust ROVVER X. Scan to read their stories.



LOCAL PRESENCE

Success in our industry is a ground game. That's why we have systems, parts inventory and capabilities strategically deployed nationwide, ready for you on demand.

TRAINING

Your operators will be productive out of the gate with on-site training from certified ROVVER X instructors. Not only do we cover equipment care, operation and safety, we're available to provide PACP training, too. Need virtual training? We deliver it on demand from a fully equipped studio.

WARRANTY

ROVVER X is backed by one of the industry's most comprehensive warranties. Optional maintenance plans and extended warranties offer further cost predictability. And with more than 25 factory-certified service centers across North America, we're never far when you need help.

TURNAROUND

Gain access to our comprehensive online parts portal, where in-stock orders placed before 3:00 pm ship the same day, with next-day delivery available. And when unique challenges require unique capabilities, know that rental gear is available from 23 locations across the continent.

5000+
crawler systems
worldwide

46
locations in
North America

4%
average yearly
cost of ownership
compared to purchase price

4000+
average distance
inspected per day
per crew

SPECIFICATIONS

system

ratings CE, NRTL
 power 120-240 Vac, 60 Hz
 viewing capability pipelines 4–96" dia.
 operating temp 32 to 104°F
 storage temp -4 to 158°F

camera (RCX90 HD)

sensitivity 0.05 lux
 resolution 1920 x 1080 pixels
 zoom lens 120x (10x optical, 12x digital)
 pressure rating 1 bar
 protection class IP68
 features auto shutter, auto/manual focus
 illumination dimmable LED, dual mode
 articulation ±135 deg tilt; infinite pan
 measurement twin laser diodes spaced 1.97"
 sensing temperature, pressure, pan/tilt
 size 6.6"x3.2"x2.8" (168x81x72 mm)
 weight 3.3 lb (1.5 kg)
 materials aluminum, stainless steel

crawler (RX130 HD, RX130L HD)

drivetrain steerable 6-wheel drive
 turn radius down to 0.0"
 camera color rear-view with tri-LED lamp
 sensors pitch, roll, temperature, pressure
 pressure rating 1 bar
 protection class IP68
 size (130) 12.2"x4.3"x3.5" (310x110x90 mm)
 size (130L) 15.1"x5.0"x4.6" (384x126x117 mm)
 weight (130) 13.2 lb (6 kg)
 weight (130L) 17.6 lb (8 kg)
 lift range (130L) 7.1" (180 mm)
 materials aluminum, stainless steel
 sonde transmitter 33kHz/512Hz/640Hz

control pendant (VC500 HD)

controls joysticks, touchscreen, power, stop
 touchscreen 10.1" color TFT, multi-touch,
 1280x800 px, 1280 cd/m², 150-deg view angle
 video capture MPEG-4 AVC (H.256)
 image capture JPEG or PNG
 internal storage 128 GB
 connectivity LAN, USB 2, USB 3, Wi-Fi, HDMI
 protection class IP55
 size 11.8"x10.5"x2.8" (300x267x71 mm)
 weight 4 lb (1.81 kg)
 housing plastic (ABS, PC), IP55-rated

auxiliary lamp (RAL200 HD, optional)

forward illumination twin tri-LED lamps
 camera color rear-view with tri-LED lamp
 sonde transmitter 33 kHz / 512 Hz
 protection class IP68
 dims 2.8"x1.3"x4.0" (72x33x102 mm)
 weight 1.3 lb (0.6 kg)
 materials aluminum, stainless steel



explosion-proof
 models available

cable reel (RAX300 HD)

cable length 984' (300 m)
 cable diameter ¼" (6.5 mm)
 cable weight 0.03 lb/ft
 cable strength 1000 lb
 cable conductors 6
 controls (local) power, emergency stop
 controls (via pendant) auto/manual, speed,
 forward/reverse, pull strength
 sensors tension, tilt
 size 24.6"x14.5"x22.6" (625x368x575 mm)
 protection class IP44
 weight 123.4 lb (56 kg)
 connections pendant, service, video in/out

camera lift (optional)

lift range 7.1" (180 mm)
 materials aluminum, stainless steel

carriage (optional)

wheelbase (w/l) 14.5"/12.2" (368/310 mm)
 weight 34.2 lb (15.5 kg)
 materials aluminum, stainless steel

TYPICAL SYSTEM

- RX130 HD crawler body
- RCX90 HD camera head
- RAX300 HD reel with 984' cable
- VC500 HD control pendant
- WinCan VX software (basic)
- handheld wireless remote control
- assortment of wheels
- transport case(s)
- tools



Request a FREE
 On-site Demo



www.envirosight.com • (866) 936.8476

©2022 Envirosight, LLC. All rights reserved.

Specifications subject to change without notice.

The ROVVER X, Flexspec and Envirosight names and logos are trademarks of Envirosight. Patents and patents pending.

**PAGE
INTENTIONALLY
BLANK**



QUOTE

QUOTE # SECQ8572
 DATE Feb 27, 2026
 CONTRACT CUSTOMER ID # 167594
 CONTRACT # 120721-EVS

To: Blake Coker
 Town of Oakland TN
 42 Industrial Park Road
 Oakland, TN 38060
 United States

Sales Contact: Luke Vihon
 615-906-8884
 luke@secequip.com

9012322539
 bcoker@oaklandtn.gov

QUOTE STATUS	SHIPPING TERMS	DELIVERY IN DAYS	PAYMENT TERMS
Sourcewell	Customer Location	15 - 45 Days	Net Delivery

QTY	DESCRIPTION	UNIT PRICE	TOTAL PRICE
1	E-RX-SYS-Truck-Basic-HD HD System includes VC500 Controller with Vision Report Software installed, RAX300 Automatic Cable Reel with 300M (1000ft) cable, wireless remote controller, reel mounting frame, cable cleaner for RAX300 mainline reel, emergency stop cable, RX130 Quick Change version crawler with 3 sets of rubber wheels for 6" to 12" pipe diameter. RCX90 pan, tilt, zoom camera, Pressurization Kit, and Wincan VX entry license.		
4	E-080-0711-00 Medium Aggressive Wheel QC RX130		
1	E-000-0035-00 Top Manhole Cable Roller for RVX		
1	E-000-0036-00 Tyger Tail 2" for manhole bottom cable RVX		
1	Outpost Box Portable Enclosure		
1	Sourcewell Discount -\$6254.71		
1	Honda EU Generator 2000 Watt		
1	Outpost Box Montior		
1	Freight		
	SubTotal		\$122,789.41
	LARGE LINE ACCESSORIES 15"-36"		
1	E-559-3900-00 HD RAL200 LED Auxiliary Light with Backeye		

QTY	DESCRIPTION	UNIT PRICE	TOTAL PRICE
	Camera for RVX		
1	E-564-0900-05 HD / SD Elevator		
4	E-080-0704-02 XL Rubber Wheel QC RX130		
1	Sourcewell Discount -\$1432.08		
	SubTotal		\$27,209.53

This quote does not include any federal, state, or local taxes.
 * In stock equipment are subject to prior sale. *

SUBTOTAL \$149,998.94

TOTAL \$149,998.94

This Quote is valid for 30 Days.

Please contact me if I can be of further assistance.

BIRMINGHAM OFFICE

2600 Powell Avenue
 Birmingham, AL 35217
 Ph: (205) 324-3194
 Fax: (205) 324-2679

MOBILE OFFICE

2025 West I-65 Service Road North
 Mobile, AL 36618
 Ph: (251) 631-3766
 Fax: (251) 631-3768



SHELBYVILLE OFFICE

3496 Highway 241 North
 Shelbyville, TN 37165
 Ph: (615) 696-7066
 Fax: (615) 413-5323

STONECREST OFFICE

2601 South Stone Mountain Lithonia Road
 Stonecrest, Georgia 30059
 Ph: (706) 685-6900
 Fax: (706) 685-3491



STATESBORO GA OFFICE

291 Hill Avenue Blvd
 Statesboro, Georgia 30157
 Ph: (478) 545-8805

**PAGE
INTENTIONALLY
BLANK**

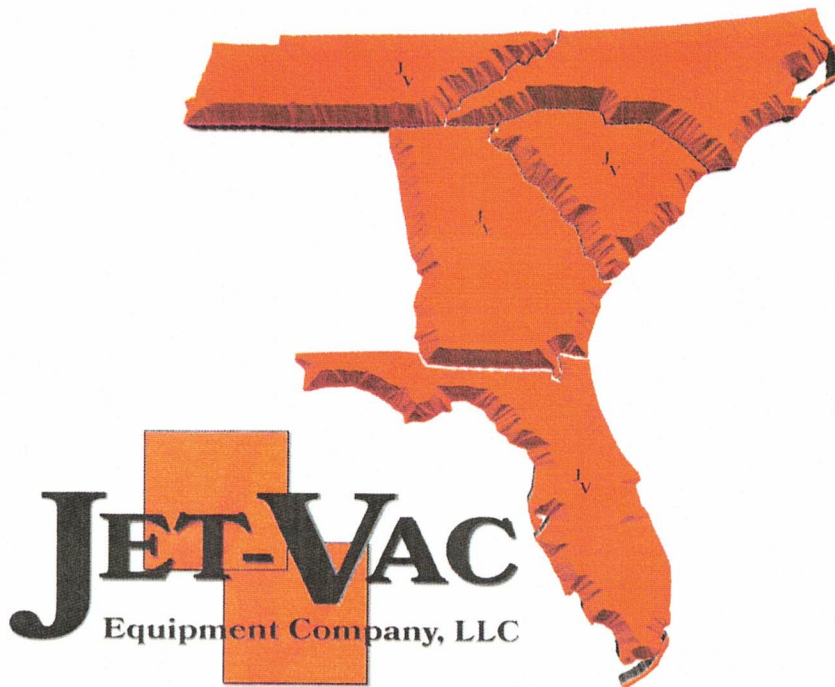

Date: 03/19/2026

Quoted To:

Town of Oakland
 Attn: Accounts Payable*
 nedmonds@oaklandtn.gov
 Oakland TN 38060

Location: COOKEVILLE

Quote Number: Q00717

Expiry Date: 04/18/2026

Salesperson: KYLE ANDERSON
 KYLE@JET-VAC.COM

Responsible: MILDRED
 EASLER

Attention: Blake Coker

We propose to furnish the equipment described herein in accord with the specification, terms, and conditions outlined.

RAPIDVIEW ECOTRAILER	26,174.00
KW Reel cabinet, (W-22", L-39" & H-34") with a slide out tray for the LISY (3) Monitor, 22" Widescreen Monitor Mount - Double Monitor Mount - Single	
ORION 3.0 Zoom HD/SD Adaptive	27,592.00
PAN & TILT CAMERA	
T76 HD TRACTOR	26,909.00
HD Camera Base Module for T76/86 Tractor	7,693.00
Remote Elevator for T76/86	9,594.00
2026 BS10XR Control Unit for CCTV Systems	38,047.00
2026 KW317 00/12/FO4 HD/4K	61,362.00
Synchronized Cable Reel w/1000' Cable	
19" Industrial PC	6,435.00

Additional Charges

EQP SOURCEWELLDISCOUNT	-8,972.76
TRAINING	5,000.00
EQP SHIPPING	2,500.00

Parts

Pressure Test S	705.00
✓ T76 8-10 ADAPT	2,347.00
IBAK Pneumatic	1,634.00
X-Large Pneumat	2,466.00
Treaded wheels	1,545.00
Tungsten Carbid	1,723.00
Tungsten Carbid	1,813.00
VESA75 MNT PLAT	41.00
DBL SOCKET ARM	49.00
9BU9" MODL TRAC	38.00
TRAC BOLT /BALL	35.00
10" TOUCH SCRNR	664.00
GRAPHIC CARD	92.00
KUV2.7 ROLLER	1,194.00
Cable Deflectio	1,011.00
Cable Deflectio	1,545.00
✓ STD/HD VID CAP	3,611.00

Comments

Sourcewell Contract #120721-RVL
 RapidView - Underground Infrastructure
 Maturity Date: 01/17/2026

Supplier reserves the right to adjust prices to reflect the impact of any tariffs, duties, or similar governmental charges imposed after the date of this proposal. These adjustments will be calculated to ensure fair allocation of the increased costs. Supplier will provide advance notice of any such adjustments along with documentation supporting the charges.

Selling Price:	222,846.24
Tax:	
Net Selling Price:	222,846.24

Accepted by:

Prepared by:

**PAGE
INTENTIONALLY
BLANK**